

# DATA SHEET

## **NE/SA/SE5532/5532A**

Internally-compensated dual low noise  
operational amplifier

Product specification

1997 Sept 29

IC11 Data Handbook

# Internally-compensated dual low noise operational amplifier

## NE/SA/SE5532/5532A

### DESCRIPTION

The 5532 is a dual high-performance low noise operational amplifier. Compared to most of the standard operational amplifiers, such as the 1458, it shows better noise performance, improved output drive capability and considerably higher small-signal and power bandwidths.

This makes the device especially suitable for application in high-quality and professional audio equipment, instrumentation and control circuits, and telephone channel amplifiers. The op amp is internally compensated for gains equal to one. If very low noise is of prime importance, it is recommended that the 5532A version be used because it has guaranteed noise voltage specifications.

### FEATURES

- Small-signal bandwidth: 10MHz
- Output drive capability: 600Ω, 10V<sub>RMS</sub>
- Input noise voltage: 5nV/√Hz (typical)
- DC voltage gain: 50000
- AC voltage gain: 2200 at 10kHz
- Power bandwidth: 140kHz
- Slew rate: 9V/μs
- Large supply voltage range: ±3 to ±20V
- Compensated for unity gain

### PIN CONFIGURATIONS

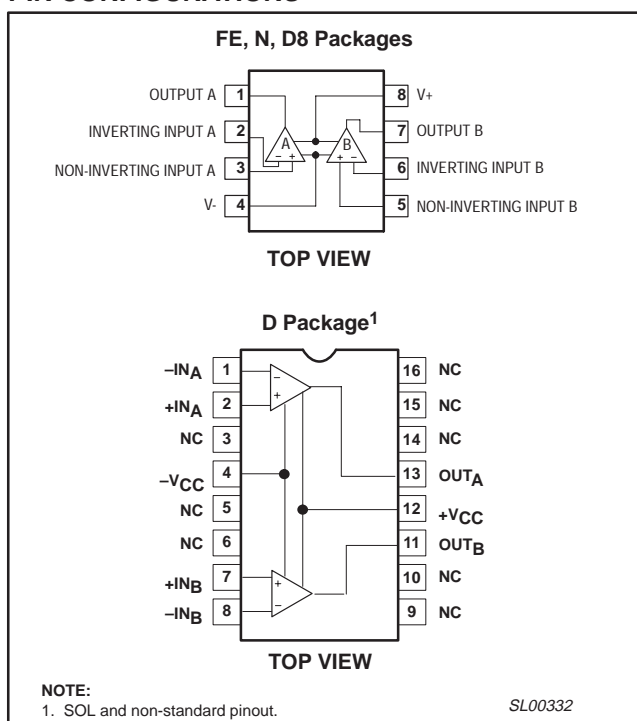

Figure 1. Pin Configurations

### ORDERING INFORMATION

DESCRIPTION	TEMPERATURE RANGE	ORDER CODE	DWG #
8-Pin Plastic Dual In-Line Package (DIP)	0 to 70°C	NE5532N	SOT97-1
8-Pin Plastic Dual In-Line Package (DIP)	-40°C to +85°C	SA5532N	SOT97-1
8-Pin Plastic Dual In-Line Package (DIP)	-40°C to +85°C	SA5532AN	SOT97-1
8-Pin Ceramic Dual In-Line Package (CERDIP)	0 to 70°C	NE5532FE	0580A
8-Pin Plastic Dual In-Line Package (DIP)	0 to 70°C	NE5532AN	SOT97-1
8-Pin Ceramic Dual In-Line Package (CERDIP)	0 to 70°C	NE5532AF	0580A
8-Pin Ceramic Dual In-Line Package (CERDIP)	-55°C to +125°C	SE5532FE	0580A
8-Pin Ceramic Dual In-Line Package (CERDIP)	-55°C to +125°C	SE5532AF	0580A
8-Pin Small Outline Package (SO)	0 to 70°C	NE5532AD8	SOT96-1
8-Pin Small Outline Package (SO)	-40°C to 85°C	SA5532D8	SOT96-1
8-Pin Small Outline Package (SO)	-40°C to 85°C	SA5532AD8	SOT96-1
8-Pin Small Outline Package (SO)	-55°C to +125°C	SE5532AD8	SOT96-1
8-Pin Small Outline Package (SO)	0 to 70°C	NE5532D8	SOT96-1
8-Pin Small Outline Package (SO)	-40°C to 85°C	SA5532D8	SOT96-1
8-Pin Small Outline Package (SO)	-40°C to 85°C	SA5532AD8	SOT96-1
8-Pin Small Outline Package (SO)	-55°C to +125°C	SE5532D8	SOT96-1
16-Pin Plastic Small Outline Large (SOL) Package	0 to 70°C	NE5532D	SOT162-1
16-Pin Plastic Dual In-Line Package (DIP)	-55°C to +125°C	SE5532N	SOT38-4

# Internally-compensated dual low noise operational amplifier

NE/SA/SE5532/5532A

## EQUIVALENT SCHEMATIC (EACH AMPLIFIER)

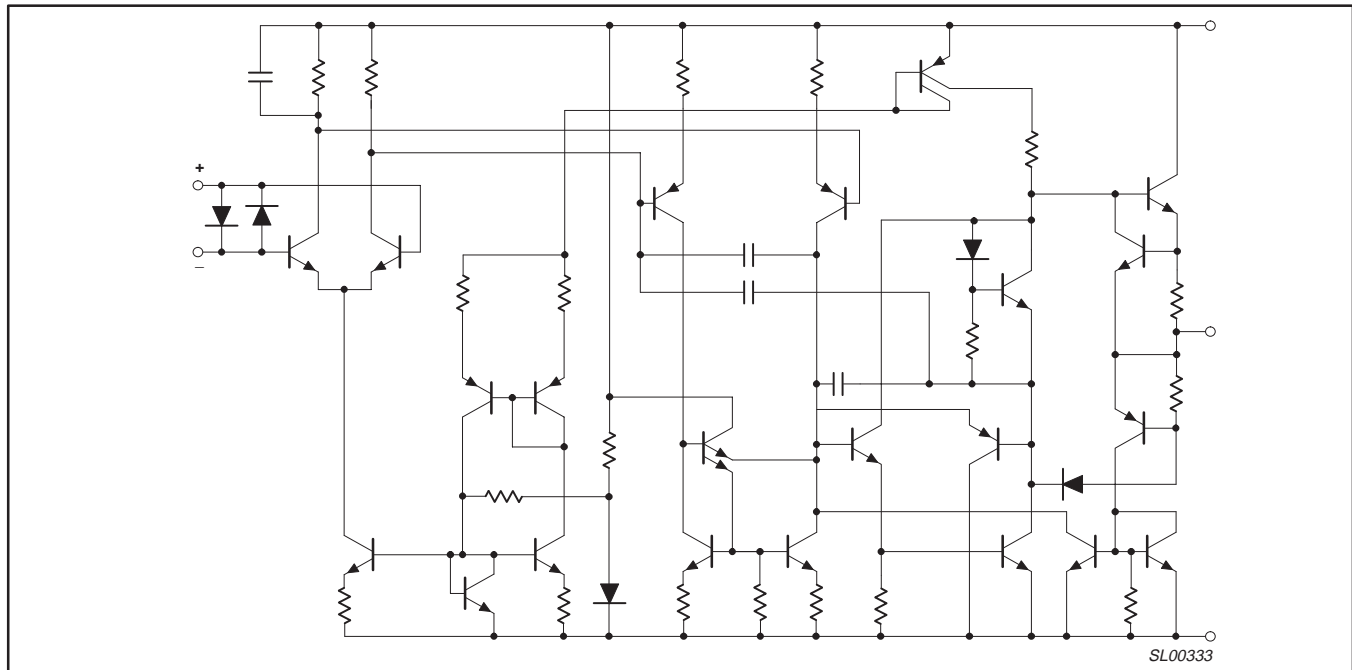

Figure 2. Equivalent Schematic (Each Amplifier)

## ABSOLUTE MAXIMUM RATINGS

SYMBOL	PARAMETER	RATING	UNIT
V <sub>S</sub>	Supply voltage	±22	V
V <sub>IN</sub>	Input voltage	±V <sub>SUPPLY</sub>	V
V <sub>DIFF</sub>	Differential input voltage <sup>1</sup>	±0.5	V
T <sub>A</sub>	Operating temperature range SA5532/A NE5532/A SE5532/A	-40 to +85 0 to 70 -55 to +125	°C °C °C
T <sub>STG</sub>	Storage temperature	-65 to +150	°C
T <sub>J</sub>	Junction temperature	150	°C
P <sub>D</sub>	Maximum power dissipation, T <sub>A</sub> =25°C (still-air) <sup>2</sup> 8 D8 package 8 N package 8 FE package 16 D package	780 1200 1000 1200	mW mW mW mW
T <sub>SOLD</sub>	Lead soldering temperature (10sec max)	300	°C

**NOTES:**

- Diodes protect the inputs against over-voltage. Therefore, unless current-limiting resistors are used, large currents will flow if the differential input voltage exceeds 0.6V. Maximum current should be limited to ±10mA.
- Thermal resistances of the above packages are as follows:  
 N package at 100°C/W  
 F package at 135°C/W  
 D package at 105°C/W  
 D8 package at 160°C/W

# Internally-compensated dual low noise operational amplifier

NE/SA/SE5532/5532A

## DC ELECTRICAL CHARACTERISTICS

 $T_A=25^\circ\text{C}$   $V_S=\pm 15\text{V}$ , unless otherwise specified. 1, 2, 3

SYMBOL	PARAMETER	TEST CONDITIONS	SE/5532/5532A			NE/SA/5532/5532A			UNIT
			Min	Typ	Max	Min	Typ	Max	
$V_{OS}$	Offset voltage	Over temperature		0.5	2		0.5	4	mV
$\Delta V_{OS}/\Delta T$				5	3		5	5	mV/ $^\circ\text{C}$
$I_{OS}$	Offset current	Over temperature			100		10	150	nA
$\Delta I_{OS}/\Delta T$				200	200		200	200	nA/ $^\circ\text{C}$
$I_B$	Input current	Over temperature		200	400		200	800	nA
$\Delta I_B/\Delta T$				5	700		5	1000	nA/ $^\circ\text{C}$
$I_{CC}$	Supply current	Over temperature		8	10.5		8	16	mA
					13				mA
$V_{CM}$	Common-mode input range		$\pm 12$	$\pm 13$		$\pm 12$	$\pm 13$		V
CMRR	Common-mode rejection ratio		80	100		70	100		dB
PSRR	Power supply rejection ratio			10	50		10	100	$\mu\text{V/V}$
$A_{VOL}$	Large-signal voltage gain	$R_L \geq 2\text{k}\Omega$ , $V_O = \pm 10\text{V}$	50	100		25	100		V/mV
		Over temperature	25			15			V/mV
		$R_L \geq 600\Omega$ , $V_O = \pm 10\text{V}$	40	50		15	50		V/mV
		Over temperature	20			10			V/mV
$V_{OUT}$	Output swing	$R_L \geq 600\Omega$	$\pm 12$	$\pm 13$		$\pm 12$	$\pm 13$		V
		Over temperature	$\pm 10$	$\pm 12$		$\pm 10$	$\pm 12$		
		$R_L \geq 600\Omega$ , $V_S = \pm 18\text{V}$	$\pm 15$	$\pm 16$		$\pm 15$	$\pm 16$		
		Over temperature	$\pm 12$	$\pm 14$		$\pm 12$	$\pm 14$		
		$R_L \geq 2\text{k}\Omega$	$\pm 13$	$\pm 13.5$		$\pm 13$	$\pm 13.5$		
Over temperature	$\pm 12$	$\pm 12.5$		$\pm 10$	$\pm 12.5$				
$R_{IN}$	Input resistance		30	300		30	300		k $\Omega$
$I_{SC}$	Output short circuit current		10	38	60	10	38	60	mA

### NOTES:

- Diodes protect the inputs against overvoltage. Therefore, unless current-limiting resistors are used, large currents will flow if the differential input voltage exceeds 0.6V. Maximum current should be limited to  $\pm 10\text{mA}$ .
- For operation at elevated temperature, derate packages based on the package thermal resistance.
- Output may be shorted to ground at  $V_S = \pm 15\text{V}$ ,  $T_A = 25^\circ\text{C}$ . Temperature and/or supply voltages must be limited to ensure dissipation rating is not exceeded.

## AC ELECTRICAL CHARACTERISTICS

 $T_A=25^\circ\text{C}$   $V_S=\pm 15\text{V}$ , unless otherwise specified.

SYMBOL	PARAMETER	TEST CONDITIONS	NE/SA/SE5532/5532A			UNIT
			Min	Typ	Max	
$R_{OUT}$	Output resistance	$A_V=30\text{dB}$ Closed-loop $f=10\text{kHz}$ , $R_L=600\Omega$		0.3		$\Omega$
	Overshoot	Voltage-follower $V_{IN}=100\text{mV}_{P-P}$ $C_L=100\text{pF}$ , $R_L=600\Omega$		10		%
$A_V$	Gain	$f=10\text{kHz}$		2.2		V/mV
GBW	Gain bandwidth product	$C_L=100\text{pF}$ , $R_L=600\Omega$		10		MHz
SR	Slew rate			9		V/ $\mu\text{s}$
	Power bandwidth	$V_{OUT}=\pm 10\text{V}$		140		kHz
		$V_{OUT}=\pm 14\text{V}$ , $R_L=600\Omega$ , $V_{CC}=\pm 18\text{V}$		100		kHz

# Internally-compensated dual low noise operational amplifier

NE/SA/SE5532/5532A

## ELECTRICAL CHARACTERISTICS

$T_A=25^\circ\text{C}$   $V_S=\pm 15\text{V}$ , unless otherwise specified.

SYMBOL	PARAMETER	TEST CONDITIONS	NE/SE5532			NE/SA/SE5532A			UNIT
			Min	Typ	Max	Min	Typ	Max	
$V_{\text{NOISE}}$	Input noise voltage	$f_O=30\text{Hz}$ $f_O=1\text{kHz}$		8			8	12	$\text{nV}/\sqrt{\text{Hz}}$
				5			5	6	$\text{nV}/\sqrt{\text{Hz}}$
$I_{\text{NOISE}}$	Input noise current	$f_O=30\text{Hz}$ $f_O=1\text{kHz}$		2.7			2.7		$\text{pA}/\sqrt{\text{Hz}}$
				0.7			0.7		$\text{pA}/\sqrt{\text{Hz}}$
	Channel separation	$f=1\text{kHz}$ , $R_S=5\text{k}\Omega$		110			110		dB

## TYPICAL PERFORMANCE CHARACTERISTICS

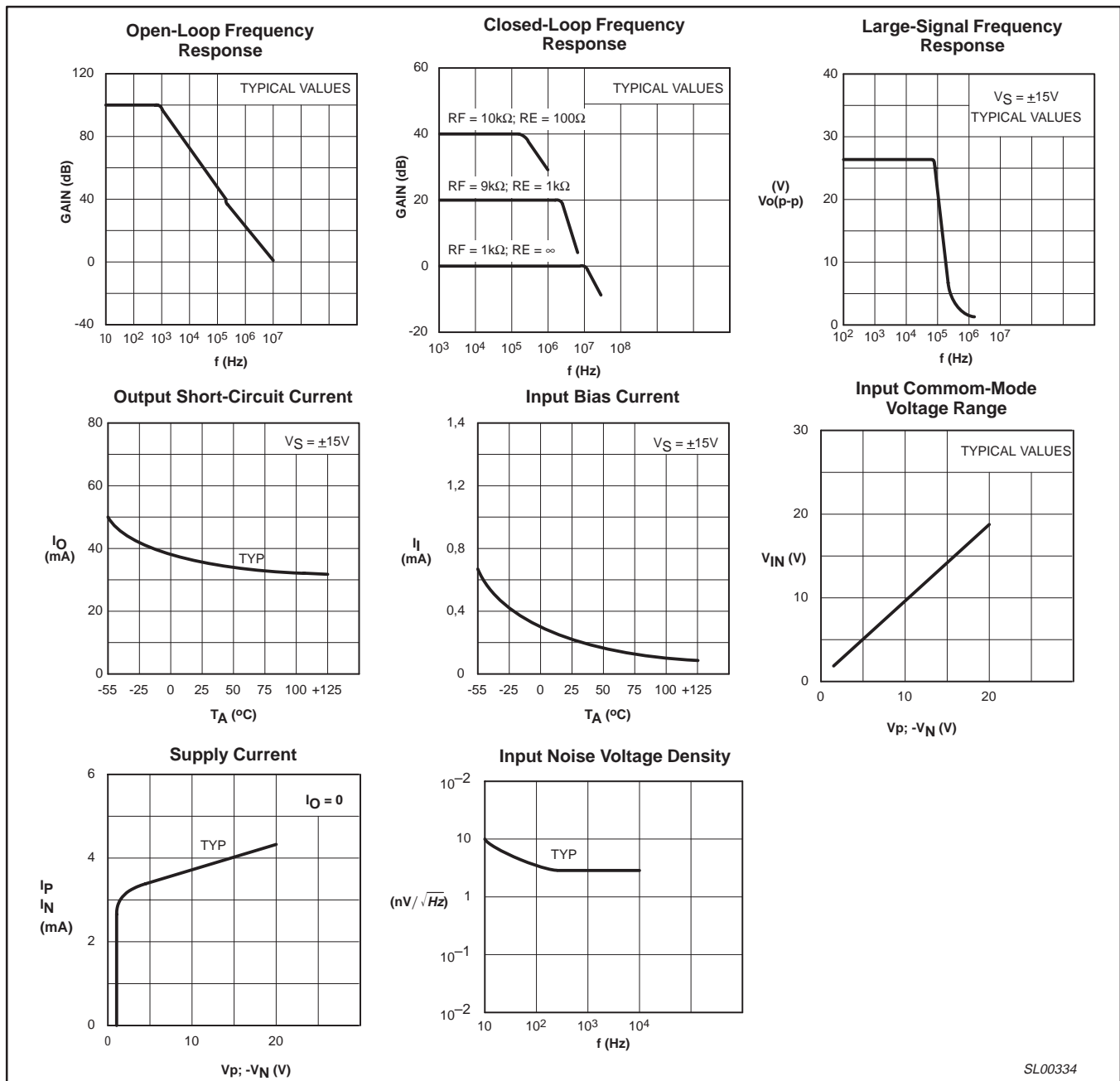

Figure 3. Typical Performance Characteristics

# Internally-compensated dual low noise operational amplifier

NE/SA/SE5532/5532A

## TEST CIRCUITS

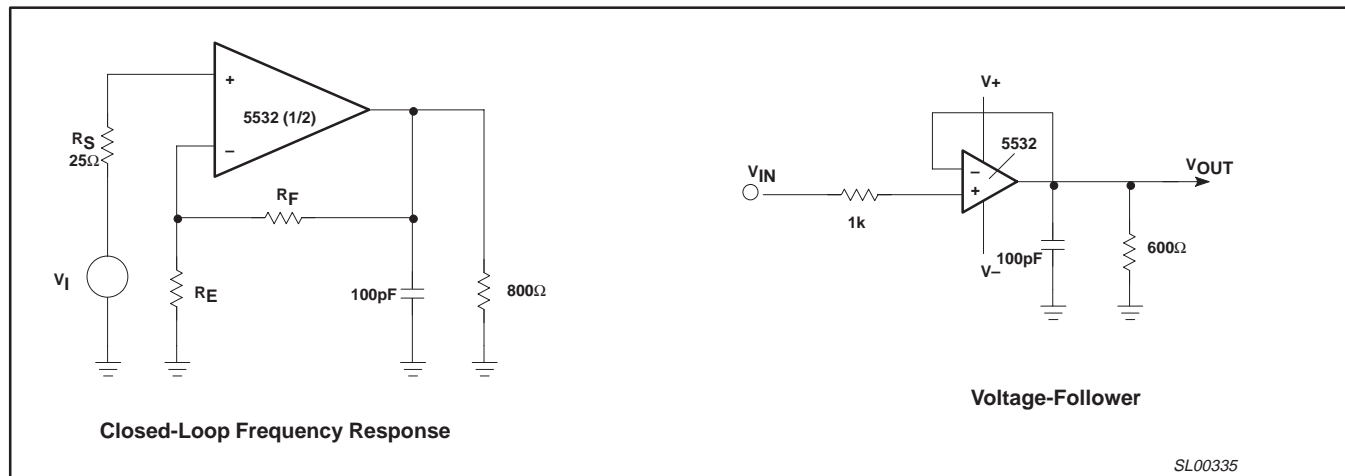

Figure 4. Test Circuits

# Internally-compensated dual low noise operational amplifier

NE/SA/SE5532/5532A

DIP8: plastic dual in-line package; 8 leads (300 mil)

SOT97-1

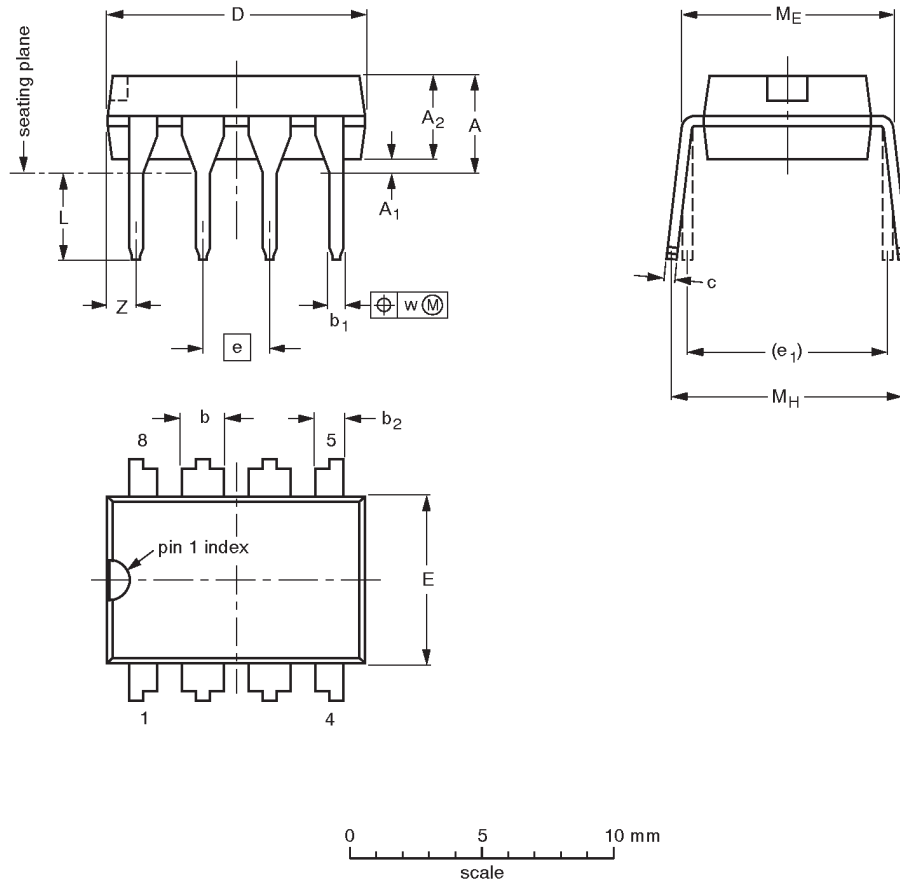

DIMENSIONS (inch dimensions are derived from the original mm dimensions)

UNIT	A max.	A <sub>1</sub> min.	A <sub>2</sub> max.	b	b <sub>1</sub>	b <sub>2</sub>	c	D <sup>(1)</sup>	E <sup>(1)</sup>	e	e <sub>1</sub>	L	M <sub>E</sub>	M <sub>H</sub>	w	Z <sup>(1)</sup> max.
mm	4.2	0.51	3.2	1.73 1.14	0.53 0.38	1.07 0.89	0.36 0.23	9.8 9.2	6.48 6.20	2.54	7.62	3.60 3.05	8.25 7.80	10.0 8.3	0.254	1.15
inches	0.17	0.020	0.13	0.068 0.045	0.021 0.015	0.042 0.035	0.014 0.009	0.39 0.36	0.26 0.24	0.10	0.30	0.14 0.12	0.32 0.31	0.39 0.33	0.01	0.045

**Note**

1. Plastic or metal protrusions of 0.25 mm maximum per side are not included.

OUTLINE VERSION	REFERENCES			EUROPEAN PROJECTION	ISSUE DATE
	IEC	JEDEC	EIAJ		
SOT97-1	050G01	MO-001AN			92-11-17 95-02-04



# Internally-compensated dual low noise operational amplifier

NE/SA/SE5532/5532A

**SO8: plastic small outline package; 8 leads; body width 3.9mm**

**SOT96-1**

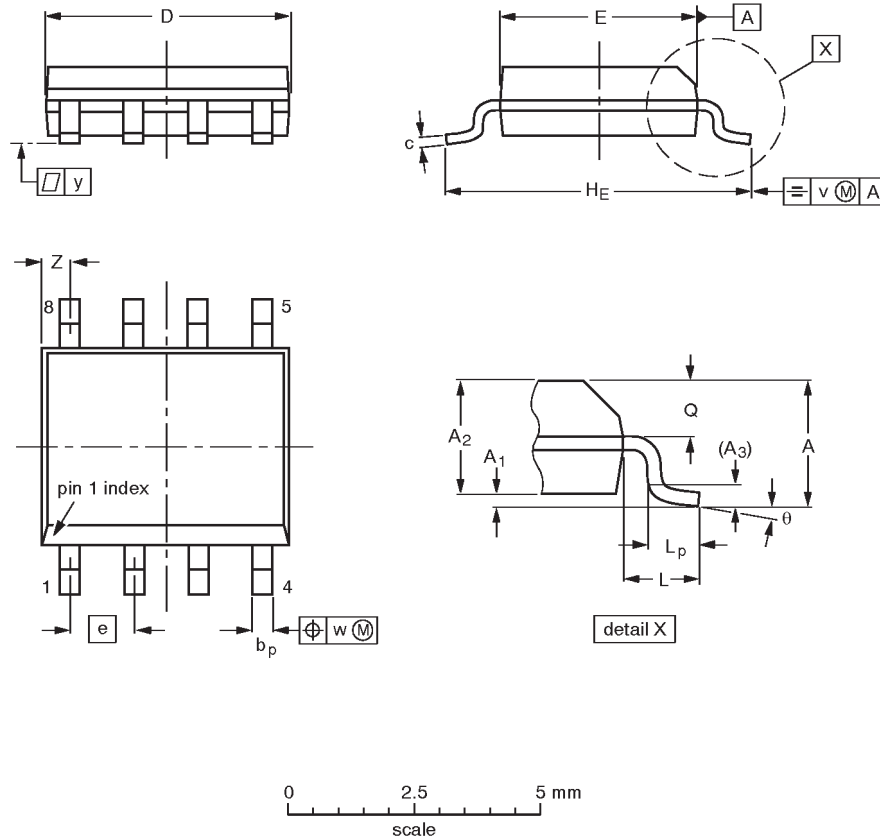

**DIMENSIONS (inch dimensions are derived from the original mm dimensions)**

UNIT	A max.	A <sub>1</sub>	A <sub>2</sub>	A <sub>3</sub>	b <sub>p</sub>	c	D <sup>(1)</sup>	E <sup>(2)</sup>	e	H <sub>E</sub>	L	L <sub>p</sub>	Q	v	w	y	Z <sup>(1)</sup>	θ
mm	1.75	0.25 0.10	1.45 1.25	0.25	0.49 0.36	0.25 0.19	5.0 4.8	4.0 3.8	1.27	6.2 5.8	1.05	1.0 0.4	0.7 0.6	0.25	0.25	0.1	0.7 0.3	8° 0°
inches	0.069	0.0098 0.0039	0.057 0.049	0.01	0.019 0.014	0.0098 0.0075	0.20 0.19	0.16 0.15	0.050	0.24 0.23	0.041	0.039 0.016	0.028 0.024	0.01	0.01	0.004	0.028 0.012	

**Notes**

1. Plastic or metal protrusions of 0.15 mm maximum per side are not included.
2. Plastic or metal protrusions of 0.25 mm maximum per side are not included.

OUTLINE VERSION	REFERENCES				EUROPEAN PROJECTION	ISSUE DATE
	IEC	JEDEC	EIAJ			
SOT96-1	076E03S	MS-012AA				92-11-17 95-02-04

# Internally-compensated dual low noise operational amplifier

NE/SA/SE5532/5532A

SO16: plastic small outline package; 16 leads; body width 7.5 mm

SOT162-1

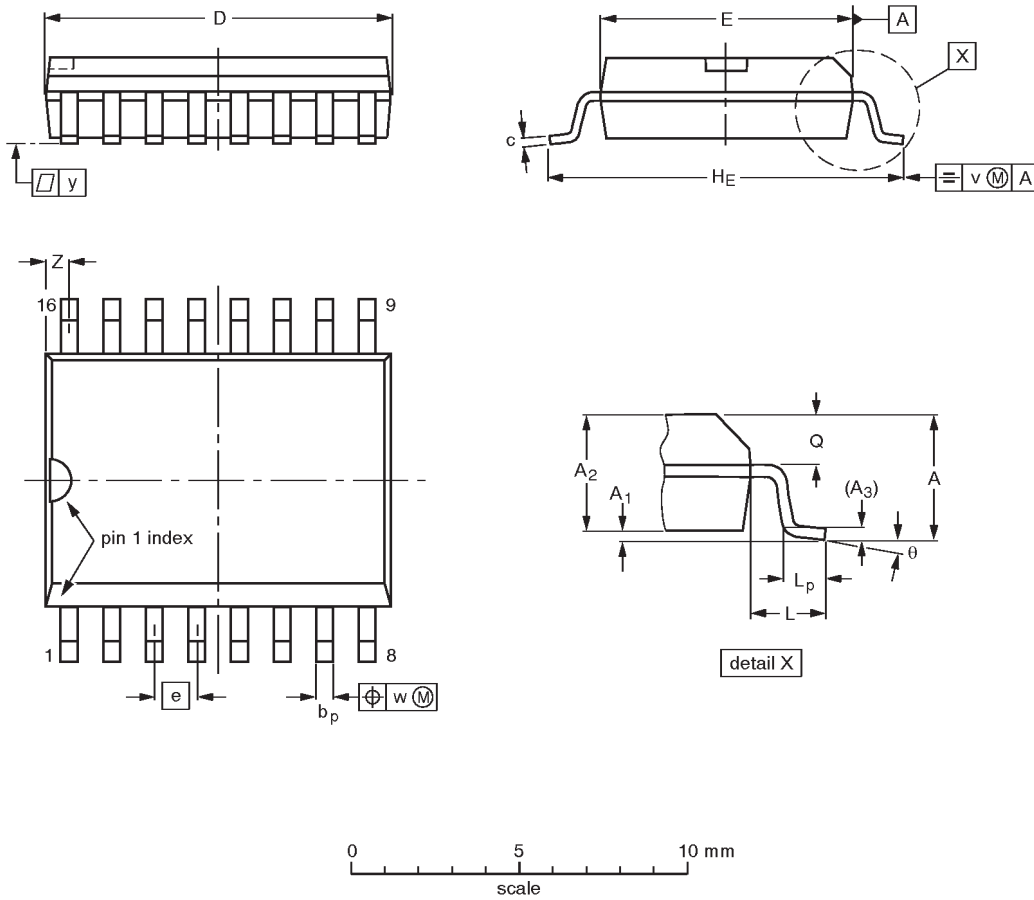

DIMENSIONS (inch dimensions are derived from the original mm dimensions)

UNIT	A max.	A <sub>1</sub>	A <sub>2</sub>	A <sub>3</sub>	b <sub>p</sub>	c	D <sup>(1)</sup>	E <sup>(1)</sup>	e	H <sub>E</sub>	L	L <sub>p</sub>	Q	v	w	y	Z <sup>(1)</sup>	θ
mm	2.65	0.30 0.10	2.45 2.25	0.25	0.49 0.36	0.32 0.23	10.5 10.1	7.6 7.4	1.27	10.65 10.00	1.4	1.1 0.4	1.1 1.0	0.25	0.25	0.1	0.9 0.4	8° 0°
inches	0.10	0.012 0.004	0.096 0.089	0.01	0.019 0.014	0.013 0.009	0.41 0.40	0.30 0.29	0.050	0.42 0.39	0.055	0.043 0.016	0.043 0.039	0.01	0.01	0.004	0.035 0.016	

Note

1. Plastic or metal protrusions of 0.15 mm maximum per side are not included.

OUTLINE VERSION	REFERENCES				EUROPEAN PROJECTION	ISSUE DATE
	IEC	JEDEC	EIAJ			
SOT162-1	075E03	MS-013AA				-92-11-17 95-01-24

# Internally-compensated dual low noise operational amplifier

NE/SA/SE5532/5532A

DIP16: plastic dual in-line package; 16 leads (300 mil)

SOT38-4

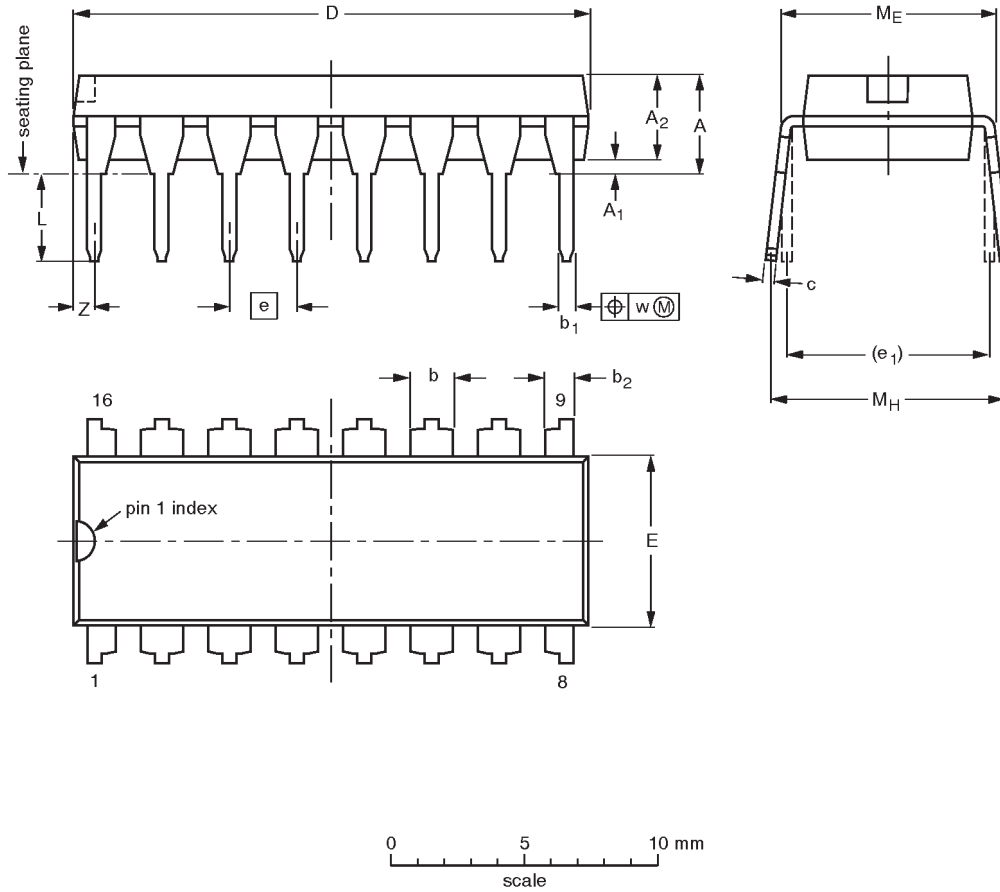

**DIMENSIONS (inch dimensions are derived from the original mm dimensions)**

UNIT	A max.	A <sub>1</sub> min.	A <sub>2</sub> max.	b	b <sub>1</sub>	b <sub>2</sub>	c	D <sup>(1)</sup>	E <sup>(1)</sup>	e	e <sub>1</sub>	L	M <sub>E</sub>	M <sub>H</sub>	w	Z <sup>(1)</sup> max.
mm	4.2	0.51	3.2	1.73 1.30	0.53 0.38	1.25 0.85	0.36 0.23	19.50 18.55	6.48 6.20	2.54	7.62	3.60 3.05	8.25 7.80	10.0 8.3	0.254	0.76
inches	0.17	0.020	0.13	0.068 0.051	0.021 0.015	0.049 0.033	0.014 0.009	0.77 0.73	0.26 0.24	0.10	0.30	0.14 0.12	0.32 0.31	0.39 0.33	0.01	0.030

**Note**

1. Plastic or metal protrusions of 0.25 mm maximum per side are not included.

OUTLINE VERSION	REFERENCES				EUROPEAN PROJECTION	ISSUE DATE
	IEC	JEDEC	EIAJ			
SOT38-4						92-11-17 95-01-14

# Internally-compensated dual low noise operational amplifier

NE/SA/SE5532/5532A

## DEFINITIONS

Data Sheet Identification	Product Status	Definition
<i>Objective Specification</i>	<b>Formative or in Design</b>	This data sheet contains the design target or goal specifications for product development. Specifications may change in any manner without notice.
<i>Preliminary Specification</i>	<b>Preproduction Product</b>	This data sheet contains preliminary data, and supplementary data will be published at a later date. Philips Semiconductors reserves the right to make changes at any time without notice in order to improve design and supply the best possible product.
<i>Product Specification</i>	<b>Full Production</b>	This data sheet contains Final Specifications. Philips Semiconductors reserves the right to make changes at any time without notice, in order to improve design and supply the best possible product.

Philips Semiconductors and Philips Electronics North America Corporation reserve the right to make changes, without notice, in the products, including circuits, standard cells, and/or software, described or contained herein in order to improve design and/or performance. Philips Semiconductors assumes no responsibility or liability for the use of any of these products, conveys no license or title under any patent, copyright, or mask work right to these products, and makes no representations or warranties that these products are free from patent, copyright, or mask work right infringement, unless otherwise specified. Applications that are described herein for any of these products are for illustrative purposes only. Philips Semiconductors makes no representation or warranty that such applications will be suitable for the specified use without further testing or modification.

### LIFE SUPPORT APPLICATIONS

Philips Semiconductors and Philips Electronics North America Corporation Products are not designed for use in life support appliances, devices, or systems where malfunction of a Philips Semiconductors and Philips Electronics North America Corporation Product can reasonably be expected to result in a personal injury. Philips Semiconductors and Philips Electronics North America Corporation customers using or selling Philips Semiconductors and Philips Electronics North America Corporation Products for use in such applications do so at their own risk and agree to fully indemnify Philips Semiconductors and Philips Electronics North America Corporation for any damages resulting from such improper use or sale.

**Philips Semiconductors**  
**811 East Arques Avenue**  
**P.O. Box 3409**  
**Sunnyvale, California 94088-3409**  
**Telephone 800-234-7381**

© Copyright Philips Electronics North America Corporation 1997  
 All rights reserved. Printed in U.S.A.

print code

Date of release: 04-96

Document order number:

9397 750 01699

*Let's make things better.*

This datasheet has been download from:

[www.datasheetcatalog.com](http://www.datasheetcatalog.com)

Datasheets for electronics components.